



Model 383AHPF

Technical Data

- Anodized Aluminum Construction
- 1" NPT / Automatic Float Drain
- 250 PSIG Maximum Pressure
- Internal Volume (with Tie Rod / No Element): 720cc
- Buna-N O-Ring (Standard-Included)
- Total Weight: 8 lbs. (Standard Disposable Element Included)
- Flow Rate @ 100 PSIG: 361 SCFM (Maximum Recommended Flow Rate for Optimal Efficiency)
 - Based on 38-152-70CS Standard Coalescing Grade Element, 95% Efficient at 0.01 Micron
 - Higher flow rates are supported with increased initial pressure drop

Elements Available:

TRE38-152-**xxx**

Disposable Borosilicate Glass Microfiber Filter Element with Integral Support

TRE38-152-70CS – Standard Coalescing Filter Element ****Included****

SS-38-152-**xxT**

Stainless Steel Filter Element

Comes Standard with Teflon Seals "T", Add "V" for optional Viton Seals when Ordering
Micron Sizes: 005, 01, 03, 10, 25, 50, 100 and 200

TRE38-152-**xxxX1**

Reinforced Borosilicate Glass Microfiber Filter Element with Integral Support

With Exterior Stainless Steel Cage

PEL-38-152-**xx**

PEL (Polyethylene) Filter Element

Micron Sizes: 10 and 25

Replace "**xxx**" with grade or micron needed. See [Filter Element Guide](#) for more information.

Available O-Rings:

BN380AHP

Buna-N (-40°F to 250°F) **Standard - Included******

GV380AHP

Viton (-15°F to 400°F)

KZ380AHP

Perfluoroelastomer (5°F to 600°F)

GS380AHP

Silicone (-65°F to 400°F)

GE380AHP

EPDM (-65°F to 300°F)

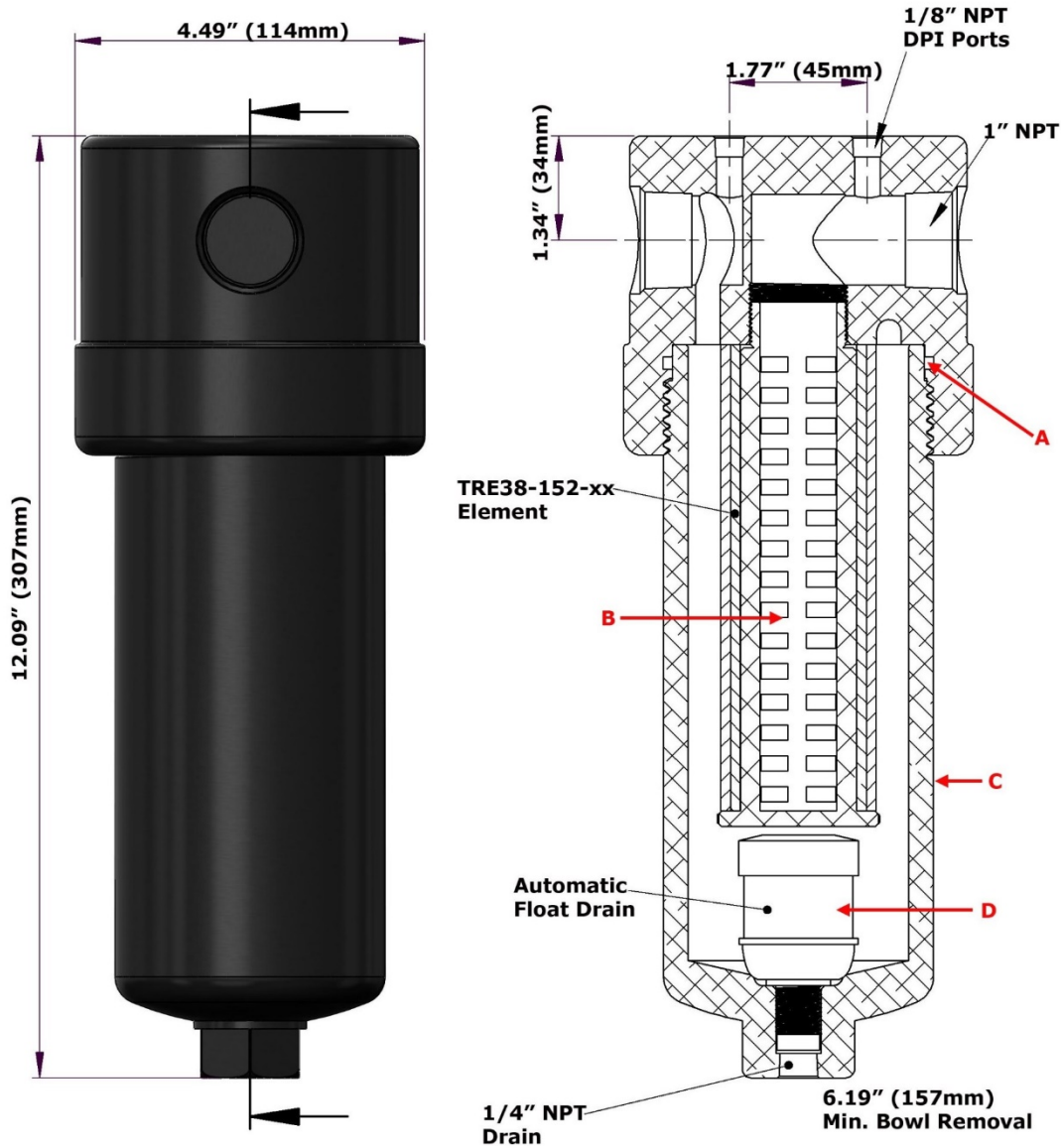

Replacement Parts:

BN380AHP	Buna-N (-40°F to 250°F) (A) **Standard - Included**
TR380	Nylon Element Retainer (B)
AB380AHP	Anodized Aluminum Bowl (C)
FD300	Nylon Automatic Float Drain (D)

Accessories:

MB380-3277-VDI	Stainless Steel Mounting Bracket (M10 x 25 Full Thread on 2.50" Center @ 90° to Port)
----------------	--