



Fast Loop Filters

PRODUCT FEATURES / BENEFITS

- ♦ 316L Stainless Steel or PTFE Construction
- ♦ Compact Design for Fast Reponse Time
- ♦ Choose from Five Housing Sizes
- ♦ Accepts Stainless Steel, PTFE and PEL Elements
- ♦ Available in Hastelloy, Monel and Etc.
- ♦ Sample Process / Remove VOCs
- ♦ Cooling Water Analysis
- ♦ Stack Gas Analyzer Protection

Fast Loop Filters are engineered to minimize the time delay commonly associated with online analyzer sample systems. Unlike traditional three-port T-type designs, our Fast Loop configurations continuously flush the filter element of heavy contaminants while filtering only the sample stream. This design significantly reduces lag time and extends filter element life.

Principle of Operation:

Fast loop filtration employs a high-flow bypass stream to continuously sweep contaminants away from the filter element, while only a small portion of the flow is directed through the element for analysis. This method is particularly effective for applications with heavy particulate loading or where sensitive analyzers require maximum protection from contamination.

Axial velocity within the housing carries bulk contaminants through the fast loop and back to the process stream. The sample stream passes radially through the filter element wall at a lower flow rate, maintaining a clean-side volume that is minimized to reduce lag time and enhance response accuracy.

Performance Recommendation:

For optimal operation and extended element life, a **minimum 4:1 flow rate ratio** between the bypass and sample streams is recommended to maintain continuous flushing and prevent element fouling.

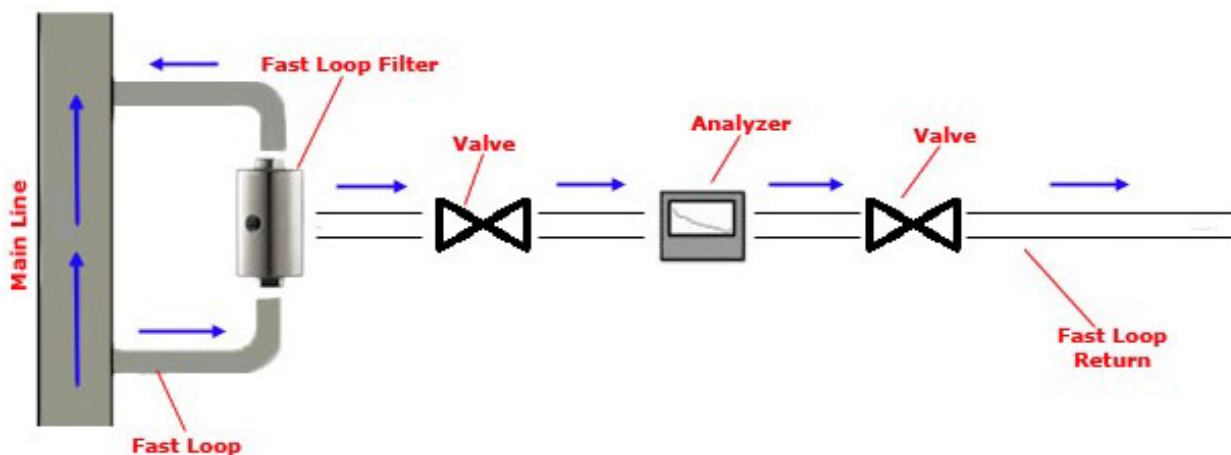

Model Number	116IL-3	126IL-3	127IL-3
Inline Port Size (NPT)	1/4"	1/4"	1/4"
Sample Port Size (NPT)	1/4"	1/4"	1/4"
Maximum Pressure (psig)	5000	5000	5000
Internal Volume (cc)	15	34	50
Annular Volume (cc)	11	15	30
Estimated Weight of Housing (lbs)	2.0	2.5	4.0
Principle Dimensions: (inches)			
Center Of Port To Inlet Port	1.39	1.89	1.61
Body Diameter	1.97	1.97	1.85
Overall Length	2.79	3.80	6.50
Element Removal Clearance	1.97	2.95	5.70
Maximum Temp. (400°F) Standard Viton O-Ring	GV126IL-3	GV126IL-3	GV127IL-3
Filter Element Codes: (1) Stainless Steel Element (Standard) **Other Elements Available-View Drawing**	SS-12-32-□	SS-12-57-□	SS-12-127-□
Drawing **For More Detail & Options**	<u>116IL-3</u>	<u>126IL-3</u>	<u>127IL-3</u>
PTFE Housing Model Maximum Temp. - 300°F, Max. Pressure - 100 PSIG	N/A	<u>126PIL-3</u>	<u>127PIL-3</u>

Notes: (1) Replace '□' with micron required, e.g. SS-12-57-03T
 (*) 127IL-3 standard with all 1/4" ports. [127IL-3-1/2"-1/4"](#) has 1/2" inlet/outlet ports, and 1/4" sample

Model Number	136IL-3	146IL-3	150IL-3-4015
Inline Port Size (NPT)	1/2"	1/2"	1"
Sample Port Size (NPT)	1/4"	1/4"	1/2"
Maximum Pressure (psig)	1500	1500	100
Internal Volume (cc)	80	215	430
Annular Volume (cc)	32	90	280
Estimated Weight of Housing (lbs)	4.0	7.5	9.0
Principle Dimensions: (inches)			
Center Of Port To Inlet Port	2.24	4.60	5.55
Body Diameter	2.50	2.50	4.06
Overall Length	4.50	9.13	11.10
Element Removal Clearance	2.95	7.87	10.27
Maximum Temp. (400°F) Standard Viton O-Ring	GV136IL-3	GV136IL-3	GV150IL-3
Filter Element Codes: (1) Stainless Steel Element (Standard) **Other Elements Available-View Drawing**	SS-25-64-□	SS-25-178-□	SS-51-230-□
Drawing **For More Detail & Options**	<u>136IL-3</u>	<u>146IL-3</u>	<u>150IL-3-4015</u>
PTFE Housing Model Maximum Temp. - 300°F, Max. Pressure - 100 PSIG	<u>136PIL-3</u>	<u>146PIL-3</u>	N/A

Notes: (1) Replace '□' with micron required, e.g. SS-25-64-03T
 (*) 150IL-3-4015 opens at both ends

Fast Loop Filter Design

The 126IL-3, 127IL-3, 136IL-3, and 146IL-3 models are machined from solid bar stock, eliminating welds and ensuring maximum durability. These housings are rated for 5,000 and 1,500 PSIG respectively, providing reliable performance in demanding applications.

Our 150IL-3 model is designed with a three-piece construction to reduce overall weight and simplify element maintenance. Both end caps are threaded to the filter body, making servicing quick and efficient.

Additionally, our SG137 and SG147 models feature a Pyrex bowl that allows for direct visual monitoring of the process. In these configurations, the traditional drain port serves as the inlet, while the original inlet functions as the fast loop outlet.

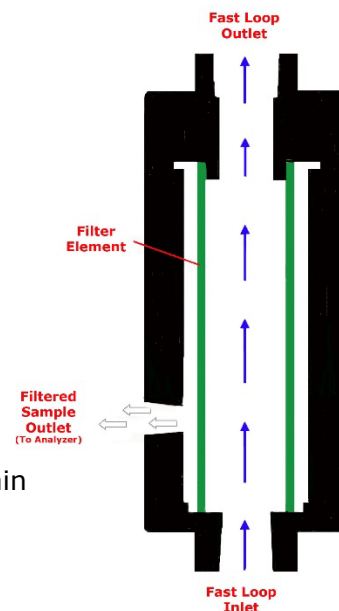

Maintaining the Filter Element

Our stainless steel filter elements are ideal for Fast Loop service, offering excellent corrosion resistance and durability to withstand continuous flushing. A key advantage of stainless steel elements is their ability to be cleaned through back-flushing, extending service life. We offer seven standard filtration grades with 98% efficiency at the following micron ratings: 01, 03, 10, 25, 50, 100, and 200. Grade 25 (25 microns) is commonly used to protect sample flows from visible particulates, while Grade 03 is recommended for removing pipe scale from steam lines. **PTFE sintered elements** are recommended in applications where sample compatibility is a concern or when PTFE Fast Loop housings are employed.

SAMPLE ANALYZER STREAM WATER FLOW RATES IN LPM AT 1.5 PSI DROP¹

Stainless Steel Micron Size	PTFE Micron Size	Housing Model Series					
		116IL-3 110 Series	126IL-3 126PIL-3 120 Series	127IL-3 127PIL-3	136IL-3 136PIL-3 130 Series	146IL-3 146PIL-3 140 Series	150IL-3 150 Series
005 (0.5 Micron)	--	.0	0.2	0.25	0.3	0.7	2.0
01 (1 Micron)	--	0.2	0.3	0.6	0.82	2.0	5.0
03 (3 Micron)	03 Micron	0.4	0.7	1.2	1.6	3.8	9.9
10 (10 Micron)	--	1.0	1.6	2.9	3.9	7.0	20.0
25 (25 Micron)	25 Micron	1.3	1.7	3.6	5.3	8.3	21.6
50 (50 Micron)	--	1.4	1.8	4.0	5.6	8.8	23.0
100 (100 Micron)	--	1.5	2.1	4.1	5.9	9.9	23.3
200 (200 Micron)	--	1.8	2.6	5.1	7.4	11.7	29.0

Notes: (1) Water Viscosity 1.002 mPa

For optimal performance, a minimum flow rate ratio of 4:1 should be maintained for continuous flushing.

Example: A model 126IL-3 equipped with an SS-12-57-10T (10-micron) element will comfortably deliver 1.6 liters per minute to the analyzer. The fast loop flow should therefore be at least 6.4 liters per minute (4×1.6).

Flow rates are generally proportional to pressure drop; if an initial pressure drop of 3 psi is acceptable, the above flow rate can be doubled. Flow rates are also inversely proportional to liquid viscosity.

Please note that disposable microfiber elements are **not recommended** for use in Fast Loop assemblies.

SCA.15.A