



Emission / Environmental

PRODUCT FEATURES / BENEFITS

- ◆ Filters for Emission Test Benches
- ◆ Heatable Housing Modules for Hot Samples
- ◆ Protect the Analyzer with A Clean Accurate Sample
- ◆ Whatman, Emfab Disc Filters – Weighing Samples
- ◆ Selective Catalytic Reduction (Acid Washed Elements)
- ◆ Light Weight, Low Cost OEM Nylon Filter Housings
- ◆ Repeatability with Our Filter Elements
- ◆ Stack Gas Monitoring

At United Filtration, we offer a comprehensive range of filtration and purification solutions for the emissions and environmental markets through our partnership with Headline Filters Ltd. and our in-house Custom Product Solutions team.

From portable analyzer protection and ambient air monitoring to emission test bench systems and heatable housing modules, our products are engineered for dependable performance at every point of use.

For convenient visual inspection, we provide Pyrex glass models designed for both visibility and durability. Our "G" Series stainless steel housings incorporate a transparent Pyrex glass bowl, allowing effortless, real-time monitoring of the emission stream.

Our extensive product line also includes disposable inline filters available in four standard sizes and a range of micron ratings to meet precise system requirements.

United Filtration's catalog is designed to deliver the optimal balance of filtration efficiency, cost-effectiveness, response time, and serviceability. We also specialize in custom-engineered filter designs to meet unique application needs. A strong commitment to maintaining a comprehensive inventory ensures reliable supply and continuous support for all ongoing filter element requirements.



Heatable Filter Housings

PRODUCT FEATURES / BENEFITS

- ◆ 316L Stainless Steel
- ◆ Specifically Designed For Hot Gas Analysis
- ◆ Bayonet Type Construction For Quick Element Change
- ◆ Integral Element Tie Rod and Retainer
- ◆ Emission Testing
- ◆ Continuous Emissions Monitoring
- ◆ Stack Gas Testing

Designed for applications such as diesel exhaust sampling and continuous emission monitoring systems (CEMS), these housings maintain sample integrity at elevated temperatures.

Operating Conditions

- Suitable for use under vacuum (sample draw) or pressurized up to 30 psig.
- Four standard models available: H122S-TR, H130S-TR, H140S-TR, H254S-TR.
- Model selection is based on required flow rate and response time.

Key Features

- Bayonet-type closure: Enables rapid element replacement in seconds, even at operating temperatures.
- Integral tie rod and retainer: Simplifies servicing.
- Element removal design: The element is connected directly to the bayonet handle, allowing it to be completely removed from the housing body for quick change-out.



Side Port Housing Model	H122S-TR	H130S-TR	H140S-TR	H254S-TR
Bottom Port Housing Model	N/A	H130-TR	H140-TR	N/A
Port Size (NPT)	1/4"	1/4"	1/4"	1/2"
Maximum Pressure (psig)	30	30	30	30
Internal Volume (cc)	55	100	240	1320
Weight of Housing (lbs)	1.5	4.0	6.0	12.0
Principle Dimensions: (inches)				
Head Diameter	1.50	2.20	2.20	3.46
Overall Length	4.72	5.31	9.80	12.80
Element Removal Clearance	4.09	4.34	8.58	11.72
Maximum Temp. (450°F) Standard Silicone O-Ring	GSH122S-TR	GSH130S-TR	GSH130S-TR	GSH254S-TR
Filter Element Codes: (1) Particulate Element (Standard) *Other Elements Available-View Drawing	12-57-□	25-64-□	25-178-□	51-254-□
Drawing **For More Detail & Options**	H122S-TR	H130S-TR	H140S-TR	H254S-TR

Notes: (1) Replace '□' with grade required, e.g. 12-57-50S

The above flow rates are for reference purposes, and are based on compressed air, not emission gases. It is recommended to start with a 70S grade filter to optimize flow, efficiency and differential pressure.

Heated Module Filter Assemblies

PRODUCT FEATURES / BENEFITS

- ◆ User Friendly Design
- ◆ Rugged Construction
- ◆ Choice of K-Type or J-Type Thermocouple
- ◆ Accepts Industry Standard Filter Cartridges
- ◆ Quick Release Bayonet-Type Closure
- ◆ 450°F Maximum Temperature (232°C)
- ◆ Automotive Emission Testing
- ◆ Continuous Emissions Monitoring
- ◆ Stack Gas Testing

UFS Heated Filter Assemblies are designed specifically for engine testing, continuous emissions monitoring (CEMS), and stack gas sampling.

Our simple, field-friendly design incorporates a form-fitted silicone heating jacket that eliminates cold spots and provides fast, uniform heat transfer. If maintenance is ever required, the heating jacket can be easily replaced in the field.

Product Highlights

- Three standard sizes available to handle a wide range of flow requirements
- Compatible with industry-standard filter cartridges to minimize inventory
- Choice of J-Type or K-Type thermocouples
- Optional dual thermocouples for redundancy in case of failure
- ¼-turn bayonet handle for quick, safe filter cartridge replacement—even at operating temperature

The entire unit is housed in a durable high-temperature thermoplastic enclosure rated up to 450°F, which can be mounted in either **vertical or horizontal orientations**.



J-TYPE Thermocouple	HFM-H130STR-HJ	HFM-H140STR-HJ	HFM-H254STR-HJ
K-TYPE Thermocouple	HFM-H130STR-HK	HFM-H140STR-HK	HFM-H254STR-HK
Port Connection	SS Tube Fitting for 3/8" Tube	SS Tube Fitting for 3/8" Tube	SS Tube Fitting for 1/2" Tube
Maximum Pressure (psig)	30	30	30
Maximum Temperature (°F)	450	450	450
Internal Volume (cc)	85	235	1030
Weight of Housing (lbs)	9.0	13.0	24.0
Principle Dimensions: (inches)			
Diameter of Heat Module	4.75	4.75	6.63
Overall Length w/ Handle	11.50	16.00	19.00
Overall Length without Handle	8.50	13.00	16.00
Base Plate Dimensions	6.00 Square	6.00 Square	8.00 Square
Element Removal Clearance	5.34	9.58	12.72
Filter Element Codes:			
Particulate Element (Standard)	25-64-□S	25-178-□S	51-254-□S
*Other Elements Available- View Drawing			
Volts	120	120	120
Amps	1.5	1.5	1.5
Watts	180	180	180
Frequency	50/60 Hz	50/60 Hz	50/60 Hz

Tube Stubs Supplied per Customer Specifications

Heated Module Controller

For a complete turnkey solution, we offer a digital temperature controller package designed for precision and reliability.

- Accuracy: Maintains temperature within $\pm 1\%$ of the set point.
- Smart Cycling: Once the set point is reached, the controller shuts off and will not restart until the temperature falls by 5°F, preventing unnecessary cycling.
- Safety Alarm: An audible alarm activates if the temperature rises more than 15°F above the set point, ensuring safe operation.

This option allows us to deliver a fully integrated, ready-to-use system tailored to your application.

Two Models Available:

Model #HFM-Controller-SDC-J
Model #HFM-Controller-SDC-K



Product Highlights:

- Affordable and Compact
- Compatible with a wide range of heaters and applications
- Easy-to-use programmable digital controller, self-contained, plug and play design
- Includes thermocouple and power output cords

Specifications:

- Small Unit Size:
 - 5.5 in L x 4.25 in W x 1.75 in H
 - 140mm L x 108mm W x 45mm H
- On-Off control
- Temperature Control Range: 32-999°F (°F models) or 0-700°C (°C models)
 - Accuracy: +/- 1% FS
- Includes J-type or K-type thermocouple sensor
 - 5-foot (1.5 m) factory installed
- 120 VAC or 240VAC power input
- Relay output rated for 10A @ 240VAC
- Sensor break options
- Upper and lower limits of the setpoint can be adjusted
- Set-point value can be adjusted by using a single key
- Hysteresis adjustable between 1 and 99°F/°C
- Exposure Temperature: 32-158°F (0-70°C)
 - 80% humidity non-condensing
- 5-foot (1.5 m) input power cord
 - 120VAC unit = NEMA 5-15 plug
 - 240VAC unit = NEMA 6-15 plug
- 5-foot (1.5 m) output power cord
 - 120VAC unit = NEMA 5-15R receptacle
 - 240VAC unit = NEMA 6-15R receptacle
- Internal buzzer for alarm condition / error

Ordering information

To discuss your application requirements and place your order please contact us at **1-800-311-5561**.

We maintain inventory on an **extensive range of components**, allowing us to build your heated module to order – please allow a minimum of three weeks ARO. For expedited service please consult us directly.

When ordering, please specify your **fitting/connection requirements** to ensure proper configuration.

As part of our quality assurance, each module is **tested for 24 hours prior to shipment** to guarantee reliable performance.

Low Pressure Stainless Steel Housing

PRODUCT FEATURES / BENEFITS

- ◆ Low Cost Design For Low Pressure Applications
- ◆ All 316L Stainless Steel
- ◆ 1/4" NPT Drain (Standard)
- ◆ Sample Conditioning Filtration
- ◆ Emission / Environmental Service
- ◆ Gas Analysis Protection
- ◆ Low Pressure Service
- ◆ No Tools Required to Service

Designed for gas analysis, emissions monitoring, CEMS, and sample process filtration, these low-pressure stainless steel housings are ideal for applications requiring continuous monitoring. While the all-stainless steel construction eliminates direct visual monitoring capability, it provides a cost-effective and durable solution for systems requiring fully stainless wetted components.

The housings feature minimal annular volume to reduce lag time and sample carryover. A 1/4" drain port located in the base allows the units to also be used in bypass or slipstream filtration configurations.

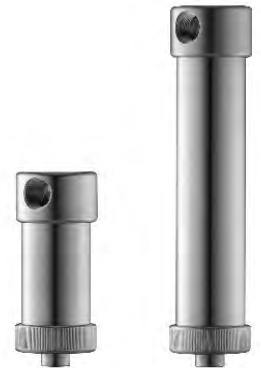

Housing Model	137	138	147	148
Port Size (NPT)	1/4"	1/2"	1/4"	1/2"
Drain Type (NPT)	1/4"	1/4"	1/4"	1/4"
Maximum Pressure (psig)	150	150	150	150
Internal Volume (cc)	105	105	260	260
Weight of Housing (lbs)	2.5	2.5	3.5	3.5
Principle Dimensions: (inches)				
Center Of Port To Head	0.59	0.59	0.59	0.59
Head Diameter	2.20	2.20	2.20	2.20
Overall Length	5.15	5.15	9.81	9.81
Element Removal Clearance	3.15	3.15	7.56	7.56
Maximum Temp. (400°F)				
Standard Viton O-Ring	GV137	GV137	GV137	GV137
Filter Element Codes: (1)				
Disposable Element (Standard)	25-64-□	25-64-□	25-178-□	25-178-□
*Other Elements Available-View Drawing				
Drawing	<u>137</u>	<u>138</u>	<u>147</u>	<u>148</u>
For More Detail & Options				

Notes: (1) Replace '□' with grade required, e.g. 25-64-50C

Low Pressure SS Pyrex Glass Bowl Housing

PRODUCT FEATURES / BENEFITS

- ◆ Low Cost Design For Low Pressure Applications
- ◆ All 316L Stainless Steel
- ◆ Pyrex Bowl for At A Glance Observations
- ◆ 1/4" NPT Drain (Standard)
- ◆ Sample Conditioning Filtration
- ◆ Emission / Environmental Service
- ◆ Gas Analysis Protection
- ◆ Low Pressure Service
- ◆ Point-Of-Use Monitors
- ◆ No Tools Required to Service

Designed for gas analysis, emissions monitoring, CEMS, and sample process filtration applications where continuous monitoring is required. The Pyrex glass "G" bowl provides full visibility of the filter element, allowing quick and convenient visual inspection.

All-stainless steel housings (designated without the "G" suffix) eliminate visual monitoring capability but offer a cost-effective solution for systems requiring all stainless steel wetted components.

The housing design features minimal annular volume to reduce lag time and sample carryover. A 1/4" drain port located in the base allows these units to be utilized in bypass or slipstream filtration configurations.



Housing Model	117G	127G	137G	138G	147G	148G
Port Size (NPT)	1/4"	1/4"	1/4"	1/2"	1/4"	1/2"
Drain Type (NPT)	1/8"	1/8"	1/4"	1/4"	1/4"	1/4"
Maximum Pressure (psig)	100	100	100	100	100	100
Internal Volume (cc)	28	40	105	105	260	260
Weight of Housing (lbs)	1.0	1.0	2.0	2.0	3.0	3.0
Principle Dimensions: (inches)						
Center Of Port To Head	0.47	0.47	0.59	0.59	0.59	0.59
Head Diameter	1.58	1.58	2.20	2.20	2.20	2.20
Overall Length	3.38	4.43	5.15	5.15	9.81	9.81
Element Removal Clearance	1.65	2.64	3.15	3.15	7.56	7.56
Maximum Temp. (400°F) Standard Viton O-Ring	GV127	GV127	GV137	GV137	GV137	GV137
Filter Element Codes: (1) Disposable Element (Standard) *Other Elements Available-View Drawing	12-32-□	12-57-□	25-64-□	25-64-□	25-178-□	25-178-□
Drawing **For More Detail & Options**	<u>117G</u>	<u>127G</u>	<u>137G</u>	<u>138G</u>	<u>147G</u>	<u>148G</u>

Notes: (1) Replace '□' with grade required, e.g. 25-64-50C

Filters for Emission Service

PRODUCT FEATURES / BENEFITS

- ◆ Complete Removal of Sub-Micron Contaminants
- ◆ Completely Disposable
- ◆ Suitable for Corrosive Applications
- ◆ High Flow Rates, Low Pressure Drops
- ◆ Emission Test Bench Protection
- ◆ Diesel Testing
- ◆ Analyzer Protection
- ◆ Stack Gas Testing

Ensure reliable emission test bench performance and compliance with Headline Filters microfiber elements. Protect your test standards with consistent, repeatable filter element quality.

Our disposable microfiber elements are manufactured from carefully controlled blends of borosilicate glass microfibers to the highest standards. With over 90% void volume, these elements deliver outstanding filtration efficiency at very low pressure drops. Designed to exceed industry requirements, they are fully compatible with standard proprietary filter housings.



For test cells operating below 300°F (150°C), our **K-Type fluorocarbon binder elements** provide proven reliability. They are the most widely used option, offering consistently low levels of adsorption. Additional grades are available, each engineered to meet specific application requirements.

K Grade	Elements are specified for particulate removal where corrosive gases and liquids are to be filtered as they have excellent chemical resistance. They are also used when highly reactive gases are being analyzed since they exhibit very low levels of adsorption.
ET Grade	Elements are hydrocarbon-free filters developed to remove particulate for automotive emission testing up to 400°F.
RPT Grade	Elements are constructed of a proprietary blend of microfiber glass and resin binders which virtually eliminate initial hydrocarbon content and fiber migration. This feature provides fast initial response times for emission analysis. These elements have the ability to function up to 650°F (342°C).
S Grade	Elements are completely inorganic and are used to filter particulate at temperatures from 300°F to 900°F.
S21-R Grade	The S21-R Type are used in diesel emission applications.
SCR Filter Elements (Acid Washed)	Acid Washed (AW) series of elements capture the excess ammonia that is introduced into the emission stream. This scrubbing is done by a chemical bond between the ammonia (NH ₃) and the acid washed (Phosphoric) filter elements, thus protecting sensitive equipment. These are commonly referred to as Selective Catalytic Reduction (SCR) Filter Elements.

Our emission elements are engineered for efficient particulate removal in automotive gas streams and other demanding analytical applications. Constructed from borosilicate microfibers, they provide high flow rates with minimal pressure drop—an essential factor in maintaining analytical accuracy. The PVDF binder forms a chemically inert, non-reactive surface, ensuring precise sample analysis even when handling highly reactive gases. With excellent chemical resistance and low adsorption characteristics, these filters are ideally suited for critical gas filtration and analytical environments.

Our advantages are well recognized and include a broader product range for greater flexibility, superior quality standards, faster delivery times, and competitive, realistic pricing. Our filter elements conform to industry-standard sizes and grades, allowing seamless use in other manufacturers’ filter housings while maintaining equivalent efficiency and performance.

K-Type

For reliable, all-around test bench protection, the 70K grade offers excellent full-range performance.

S-Type

Ideally suited for hot gas (diesel) testing applications operating above 300 °F. The 70S grade is recommended as a full-range element for optimal performance.

RPT Type

Designed for highly sensitive testing benches that demand exceptionally low initial hydrocarbon content. For optimal performance, we recommend the 70RPT grade as a full-range element.

Part Number Element Size	Temperature Rating 0° - 300°F	Temperature Rating 300°F - 900°F	
12-57- (0.50" x 2.25")	12-57-xxK	12-57-xxS	12-57-xxRPT
25-64- (1" X 2.5")	25-64-xxK	25-64-xxS	25-64-xxRPT
25-178- (1" X 7")	25-178-xxK	25-178-xxS	25-178-xxRPT
51-230- (2" X 9")	51-230-xxK	51-230-xxS	51-230-xxRPT

Please replace the "xx" with either 50 or 70 Grade. Example: 25-178-70S

The "70" Grade element is rated at 95% efficiency against 0.01 micron particles.

The "50" Grade element is rated at 99.99% efficiency against 0.01 micron particles.

Emission Filter Housings

Heatable Housings

Designed for applications such as diesel exhaust sampling and continuous emission monitoring systems (CEMS), these housings maintain sample integrity at elevated temperatures.

- Suitable for use under vacuum (sample draw) or pressurized up to 30 psig.
- Four standard models available: H122S-TR, H130S-TR, H140S-TR, H254S-TR.
- Bayonet-type closure: Enables rapid element replacement in seconds, even at operating temperatures.
- The element is connected directly to the bayonet handle, allowing it to be completely removed from the housing body for quick change-out.



Pyrex Glass Housings for Monitoring

Low pressure monitoring our 127G-147G filters for emission testing utilize a Pyrex bowl for at-a-glance monitoring of particle build-up.

- Positive O-Ring design eliminates leak points
- No tools needed for element service



Disposable In-Line Filters & Adsorbers

Our Disposable In-Line Filters and Adsorbers are ideal for portable analyzers and systems requiring an easily last chance protection replaceable filter.

- Four sizes to choose from.
- Last chance filter ideal for portable systems.



Nylon Housings for Portable Service

Our 100% nylon housings are an inexpensive, robust solution for emission analyzer service. Typically used on portable in field applications.

- Light Weight
- No Metal Parts



Selective Catalytic Reduction Acid Wash Filter Elements

PRODUCT FEATURES / BENEFITS

- ◆ Capture Ammonia
- ◆ Protect NO_x Analyzers Using CLD
- ◆ Low Cost Disposable Filter Elements
- ◆ Remove Ammonia While Not Interfering with Other Measurements
- ◆ Measure NO_x in the Presence of Ammonia
- ◆ Emission Testing
- ◆ Meets New Standards
- ◆ Protect Analyzers from Ammonia Residue

United Filtration Systems' borosilicate microfiber, Acid Washed (AW) series elements are designed to capture excess ammonia (NH₃) introduced into the emission stream.

The scrubbing process occurs through a chemical bond between the ammonia and the acid-washed (phosphoric) filter media, effectively protecting sensitive downstream equipment.

Key Advantage

- Direct replacement design – the AW series is fully compatible with standard filter housings already in service, eliminating the need for new installations or modifications.



Part Number Element Size	Temperature Rating 0° - 300°F	Temperature Rating 300°F - 900°F
12-57- (0.50" x 2.25")	12-57-50KAW	12-57-50SAW
25-64- (1" X 2.5")	25-64-50KAW	25-64-50SAW
25-178- (1" X 7")	25-178-50KAW	25-178-50SAW

The "50" Grade element is rated at 99.99% efficiency against 0.01 micron particles.

The "70" Grade element is rated at 95% efficiency against 0.01 micron particles.

Please allow 5 days for delivery of the Acid Washed elements.
For further information, please contact United Filtration Systems at 1-800-311-5561.

Diesel Particulate Filters

PRODUCT FEATURES / BENEFITS

- ♦ Whatman for Certification PM Sampling
- ♦ Meets Heavy Duty Emissions Standards
- ♦ Pallflex PM Filters
- ♦ Ideal for Ambient PM Sampling
- ♦ UFS Offers One Stop Shopping for your Emission Lab Consumables

This product line is widely used in:

- Diesel particulate testing (for compliance and certification)
- Ambient air monitoring
- Stack emission control

The pure formulation of these filters ensures fast, accurate sampling results. Commonly referred to as "*diesel particulate*" or "*weigh room*" filters, they are designed to pair seamlessly with our borosilicate microfiber emission double open-ended elements.

We maintain a broad inventory of industry-standard sizes for immediate delivery.



Description	Pall Emfab Filters TX40H120-WW
Filter Media	Borosilicate microfibers reinforced with woven glass cloth and bonded with PTFE
Diameters Available	46.2mm, 47mm, 70mm, 90mm
Typical Thickness	148µm (7 mils)
Typical Filter Weight	5.0 mg/cm ²
Typical Water Flow Rated at 5 PSIG (0.35 Bar)	32 mL/min/cm ²
Typical Air Flow Rate Rated at 10 PSIG (0.7 Bar)	68 L/in/cm ²
Maximum Operating Temperature-Air	260°C (500°F)
Typical Aerosol Retention (DOP)	99.9%



**Whatman PM2.5: 2.0 micron, 46.2 mm PTFE with support ring
(Sequentially Numbered)**

Description	Whatman PM 2.5
Filter Media	PTFE Membrane
Diameter	46.2mm
Typical Thickness	40µm
Typical Air Flow Rate Rated at 16.67 L/Min	Not Applicable
Particle Retention (DOP)	99.7%
Filter Pore Size	2 µm
Support Ring Media	Polypropylene

Disposable In-Line Filters

PRODUCT FEATURES / BENEFITS

- ◆ Completely Disposable
- ◆ Available In Blue Transparent Nylon Body or High Purity Virgin Kynar Body for Enhanced Compatibility
- ◆ Four Body Sizes / Two or Three Port Design
- ◆ Five Grades of Filtration
- ◆ HVAC Protection
- ◆ Analyzer & Sensor Protection
- ◆ Low Cost Scrubbers
- ◆ Last Chance Air Purifier / Zero Air Gas Calibration

Our Disposable In-Line Filters (DIF Series) are engineered with permanently welded housings and encapsulated filter elements, making them ideal for portable analyzers and other analytical systems that demand a robust, compact, and easily replaceable filtration solution.

With a variety of body materials available, these filters are compatible with a wide range of chemical environments. The DIF Series provides the high-efficiency performance of microfiber filtration for both gases and liquids, with the added benefit of complete disposability—eliminating cleaning or maintenance.

This series of disposable filters provide end-users with a convenient, ready-to-use filtration solution that minimizes equipment and process downtime through fast, tool-free replacement. Each unit features a permanently welded housing, supplied fully assembled for immediate installation. A wide range of filter element grades and media types are available.

Key Features:

- Welded, leak-proof construction
- Compact, disposable design
- High-efficiency microfiber elements
- Optional PTFE or stainless-steel media
- Wide chemical compatibility
- Multiple connection/barb options
- Fully customizable—even in low quantities



Specialized Filtration Solutions

We offer the flexibility to incorporate unique barb sizes and filter designs to meet specific application requirements.

For unique applications, we offer alternative media options such as PTFE membranes for fine separation and stainless-steel screens for coarse filtration.

Whether you need a perforated screen for coarse filtration or a membrane for precision separation, we can tailor solutions to your specifications—across all body sizes.

Custom solutions are available and built to order with quick turnaround times, regardless of quantity. From standard needs to highly specialized requirements, we're ready to deliver.



 **Contact us today for a fast, comprehensive quote—no minimum order required.**

Miniature Size with Microfiber Element

The DIF-MN (Mini Disposable In-Line Filter) is engineered as a final "last chance" filter for critical equipment where space is limited and performance is essential. With its compact footprint, the DIF-MN is ideal for protecting sensitive systems in HVAC and pneumatic temperature control applications, where even the smallest contaminants can lead to costly downtime or damage.

DIF-MN__ *add grade required

Standard Grade: **DIF-MN50 (99.99% @ 0.01 Micron)** - Other Grades Available: 30, 40, 60, 70, 80

TECHNICAL INFORMATION

- 1/4" Inlet / Outlet
- 6cc of Volume
- 230°F Maximum Temp. At 0 PSIG
- 125 PSIG of Maximum Pressure at 110°F
- 100% Grilamid TR 55 Blue Nylon body
- Fluorocarbon Borosilicate Glass Microfiber Element
- Standard Gas Flow at 100 PSIG is 2.1 SCFM (Grade 50)

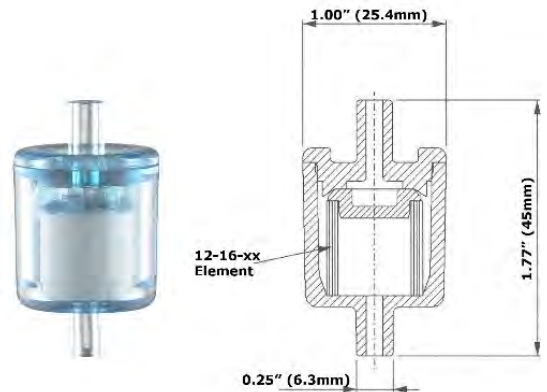

Miniature Size with 1/8" Straight Barb

Our Mini DIF is specifically engineered as a final, last-chance filter for protecting critical equipment. Designed with a compact footprint and 1/8" ID tubing, it is ideally suited for HVAC and pneumatic temperature control systems, where space is limited and performance is essential.

DIF-MN__1/8" *add grade required

Standard Grade: DIF-MN50-1/8" (99.99% @ 0.01 Micron) - Other Grades Available: 30, 40, 60, 70, 80

TECHNICAL INFORMATION

- 1/8" Tubing Connection on Inlet / Outlet
- 6cc of Volume
- 230°F Maximum Temp. At 0 PSIG
- 125 PSIG of Maximum Pressure at 110°F
- Material:
 - Body - 100% Grilamid TR 55 Blue Nylon
 - Straight Barb - White Nylon
- Fluorocarbon Borosilicate Glass Microfiber Element
- Standard Gas Flow at 100 PSIG is 2.1 SCFM (Grade 50)

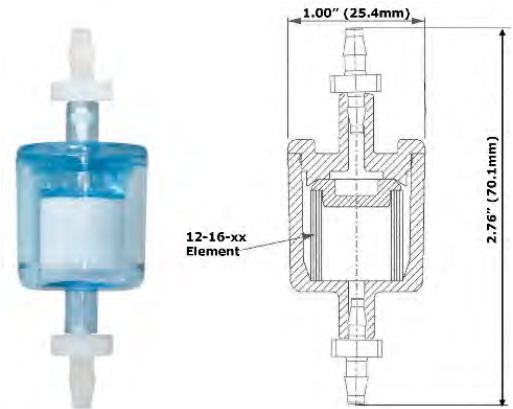

Miniature Size with 1/8" Elbow Barb

Our Mini DIF is purpose-built as a final, last-chance filter for critical equipment requiring a compact footprint and 1/8" ID tubing with a 90° inlet/outlet configuration. It is ideally suited for HVAC and pneumatic temperature control protection applications.

DIF-MN__1/8"-90 *add grade required

Standard Grade: DIF-MN50-1/8" (99.99% @ 0.01 Micron) - Other Grades Available: 30, 40, 60, 70, 80

TECHNICAL INFORMATION

- 1/8" Tubing Connection on Inlet / Outlet
- 6cc of Volume
- 230°F Maximum Temp. At 0 PSIG
- 125 PSIG of Maximum Pressure at 110°F
- Material:
 - Body - 100% Grilamid TR 55 Blue Nylon
 - Elbow Barb - White Nylon
- Fluorocarbon Borosilicate Glass Microfiber Element
- Standard Gas Flow at 100 PSIG is 2.1 SCFM (Grade 50)

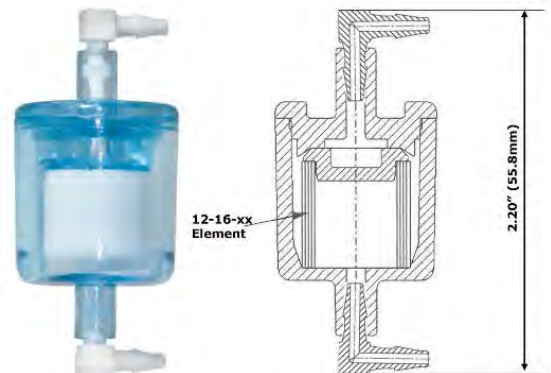

Standard OEM Size with Microfiber Element

Our standard DIF-BN series is by far the most widely used DIF size, combining high-efficiency filtration with low pressure drop in a compact, reliable package. Whether integrated into an OEM cabinet, emission bench, or air monitoring system, this versatile filter is an economic workhorse trusted across industries.

DIF-BN__ *add grade required

Standard Grade: DIF-BN50 (99.99% @ 0.01 Micron) - Other Grades Available: 30, 40, 60, 70, 80

TECHNICAL INFORMATION

- 1/4" Inlet / Outlet
- 11.5cc of Volume
- 230°F Maximum Temp. At 0 PSIG
- 125 PSIG of Maximum Pressure at 110°F
- 100% Grilamid TR 55 Blue Nylon body
- Fluorocarbon Borosilicate Glass Microfiber Element
- Standard Gas Flow at 100 PSIG is 4.2 SCFM (Grade 50)



Standard OEM Size with Stainless Steel Screen

For applications where high-efficiency microfiber elements are not required, we offer cost-effective stainless-steel screens—commonly used in portable emission analyzers, bulk contaminant removal, and liquid sampling.

DIF-BN__SS *add micron required

For Portable Emission Analyzers: DIF-BN50SS. - Other Microns Available: 05, 10, 25, 100

TECHNICAL INFORMATION

- 1/4" Inlet / Outlet
- 11.5cc of Volume
- 230°F Maximum Temp. At 0 PSIG
- 125 PSIG of Maximum Pressure at 110°F
- 100% Grilamid TR 55 Blue Nylon body
- 304 Stainless Steel Screen Element



Standard OEM Size with 1/8" Straight Barb (Short Spigot)

Our standard DIF-BN series is the most commonly used DIF size, offering high-efficiency filtration and low pressure drop in a compact design. For applications requiring 1/8" tubing—while maintaining the same footprint and dimensions—please specify DIF-BN50SP-1/8".

DIF-BN__SP-1/8" *add grade required

Standard Grade: DIF-BN50SP-1/8" (99.99% @ 0.01 Micron) - Other Grades Available: 30, 40, 60, 70, 80

TECHNICAL INFORMATION

- 1/8" Tubing Connection on Inlet / Outlet
- 11.5cc of Volume
- 230°F Maximum Temp. At 0 PSIG
- 125 PSIG of Maximum Pressure at 110°F
- Material:
 - Body - 100% Grilamid TR 55 Blue Nylon
 - Straight Barb - White Nylon
- Fluorocarbon Borosilicate Glass Microfiber Element
- Standard Gas Flow at 100 PSIG is 4.2 SCFM (Grade 50)

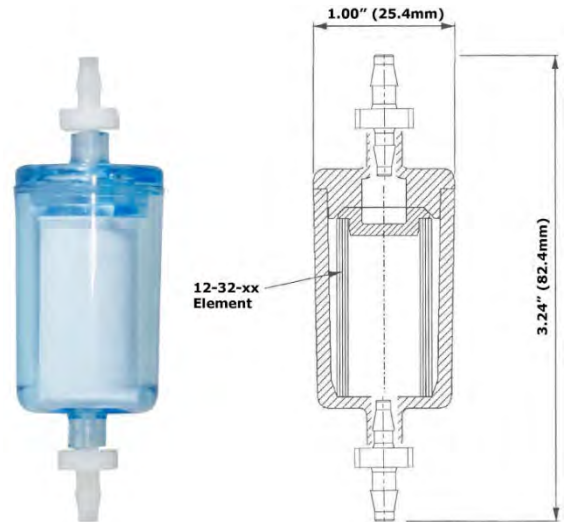

Standard OEM Size with 1/8" Elbow Barb

Our standard DIF-BN series is by far the most commonly used DIF model, combining high-efficiency filtration with low pressure drop in a compact, space-saving design. It is ideal for installations with limited tubing connection space. Combinations of different barb sizes are available upon request to suit specific application needs.

DIF-BN__1/8"-90 *add grade required

Standard Grade: DIF-BN50-1/8"-90 (99.99% @ 0.01 Micron) - Other Grades Available: 30, 40, 60, 70, 80

TECHNICAL INFORMATION

- 1/8" Tubing Connection on Inlet / Outlet
- 11.5cc of Volume
- 230°F Maximum Temp. At 0 PSIG
- 125 PSIG of Maximum Pressure at 110°F
- Material:
 - Body - 100% Grilamid TR 55 Blue Nylon
 - Elbow Barb - White Nylon
- Fluorocarbon Borosilicate Glass Microfiber Element
- Standard Gas Flow at 100 PSIG is 4.2 SCFM (Grade 50)

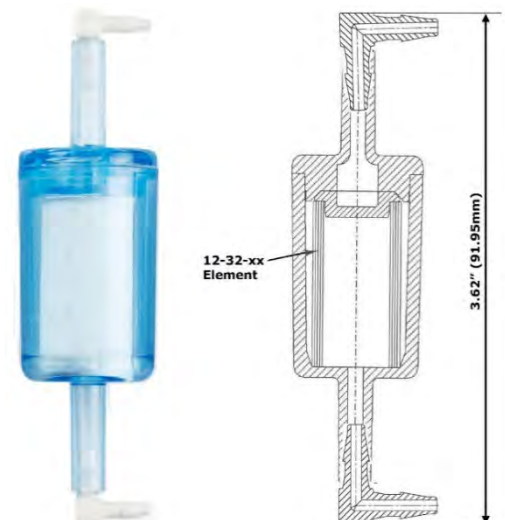

Standard OEM Size for Chemical Compatibility

This series of DIF assemblies is constructed from virgin white Kynar®(PVDF), making it ideal for use in corrosive applications. Compatible media include, but are not limited to: sulfuric acid, hydrochloric acid, chlorine (gas or liquid), hydrogen peroxide, phenol, glycol, and ethylene oxide (ETO).

DIF-BK__ *add grade required

Standard Grade: DIF-BK50 (99.99% @ 0.01 Micron) - Other Grades Available: 30, 40, 60, 70, 80

TECHNICAL INFORMATION

- 1/4" Inlet / Outlet
- 11.5cc of Volume
- 230°F Maximum Temp. At 0 PSIG
- 125 PSIG of Maximum Pressure at 110°F
- Virgin White Kynar Body
- Fluorocarbon Borosilicate Glass Microfiber Element
- Standard Gas Flow at 100 PSIG is 4.2 SCFM (Grade 50)

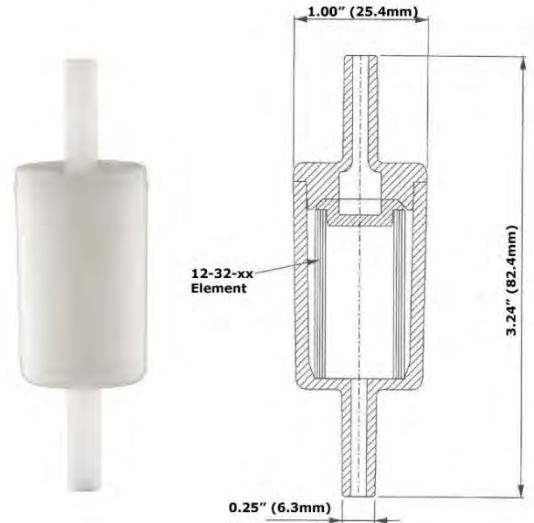

Indicating Standard OEM Size

The DIF-BN50I features a red dye indicator that provides a clear visual signal when oil is present. As the element becomes saturated, the dye permeates through the filter media, indicating oil breakthrough. A common application for this model is in HVAC control panels. This dye indicator option can also be incorporated into any of our microfiber elements upon request.

DIF-BN50I

Simply order as DIF-BN50I

TECHNICAL INFORMATION

- 1/4" Inlet / Outlet
- 11.5cc of Volume
- 230°F Maximum Temp. At 0 PSIG
- 125 PSIG of Maximum Pressure at 110°F
- 100% Grilamid TR 55 Blue Nylon body
- Fluorocarbon Borosilicate Glass Microfiber Element
- Standard Gas Flow at 100 PSIG is 4.2 SCFM (Grade 50)

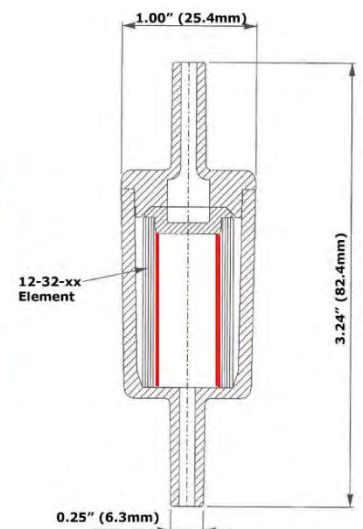

Intermediate High Flow with Microfiber Element

Our intermediate range is ideal for applications requiring higher particulate holding capacity.

DIF-IN__ *add grade required

Standard Grade: **DIF-IN50 (99.99% @ 0.01 Micron)** - Other Grades Available: 30, 40, 60, 70, 80

TECHNICAL INFORMATION

- 1/4" Inlet / Outlet
- 50cc of Volume
- 230°F Maximum Temp. At 0 PSIG
- 100 PSIG of Maximum Pressure at 110°F
- 100% Grilamid TR 55 Blue Nylon body
- Fluorocarbon Borosilicate Glass Microfiber Element
- Standard Gas Flow at 100 PSIG is 10.0 SCFM (Grade 50)

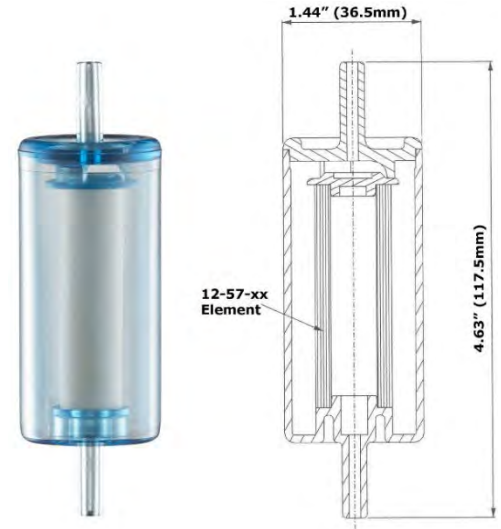

Intermediate High Flow with Stainless Steel Screen

For applications where high-efficiency microfiber elements are not required, we offer cost-effective stainless-steel screens—commonly used in portable emission analyzers, bulk contaminant removal, and liquid sampling.

DIF-IN__SS *add micron required

For Portable Emission Analyzers: **DIF-IN50SS**. - Other Microns Available: 05, 10, 25, 100

TECHNICAL INFORMATION

- 1/4" Inlet / Outlet
- 50 cc of Volume
- 230°F Maximum Temp. At 0 PSIG
- 125 PSIG of Maximum Pressure at 110°F
- 100% Grilamid TR 55 Blue Nylon body
- 304 Stainless Steel Screen Element

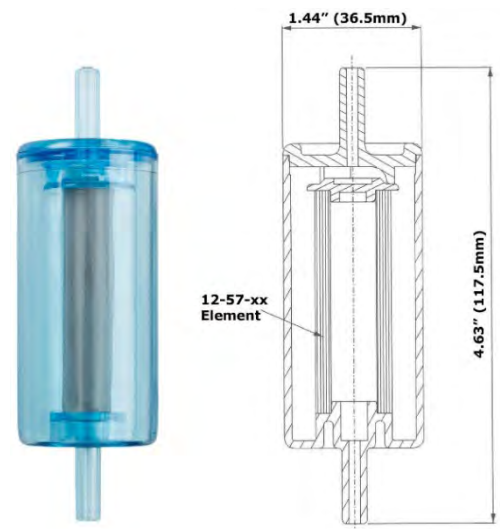

Intermediate High Flow for Chemical Compatibility

Our intermediate range is ideal for applications requiring higher particulate holding capacity.

DIF-IK__ *add grade required

Standard Grade: DIF-IK50 (99.99% @ 0.01 Micron) - Other Grades Available: 30, 40, 60, 70, 80

TECHNICAL INFORMATION

- 1/4" Inlet / Outlet
- 50cc of Volume
- 230°F Maximum Temp. At 0 PSIG
- 100 PSIG of Maximum Pressure at 110°F
- Virgin White Kynar Body
- Fluorocarbon Borosilicate Glass Microfiber Element
- Standard Gas Flow at 100 PSIG is 10.0 SCFM (Grade 50)

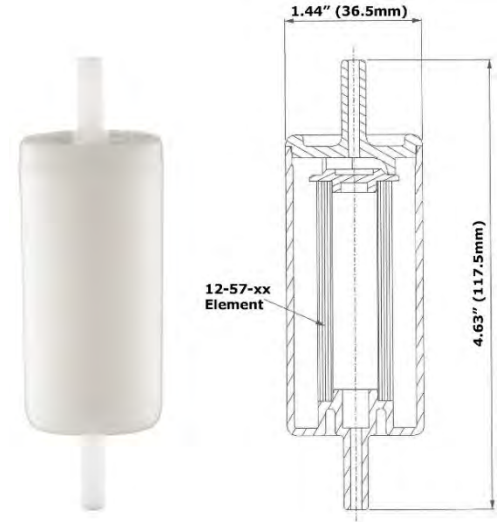

Intermediate High Flow Coalescing DIF

Our intermediate DIF model with a third spigot is designed for applications requiring coalescing (liquid removal).

New Kynar Version Available

To specify the Kynar construction, designate "IK". **Standard Grade Example:** DIF-IK50C

DIF-IN__C *add grade required

Standard Grade: DIF-IN50C (99.99% @ 0.01 Micron) - Other Grades Available: 30, 40, 60, 70, 80

TECHNICAL INFORMATION

- 1/4" Inlet, Outlet, and Drain Port
- 50cc of Volume
- 230°F Maximum Temp. At 0 PSIG
- 100 PSIG of Maximum Pressure at 110°F
- 100% Grilamid TR 55 Blue Nylon body
- Fluorocarbon Borosilicate Glass Microfiber Element
- Standard Gas Flow at 100 PSIG is 10.0 SCFM (Grade 50)

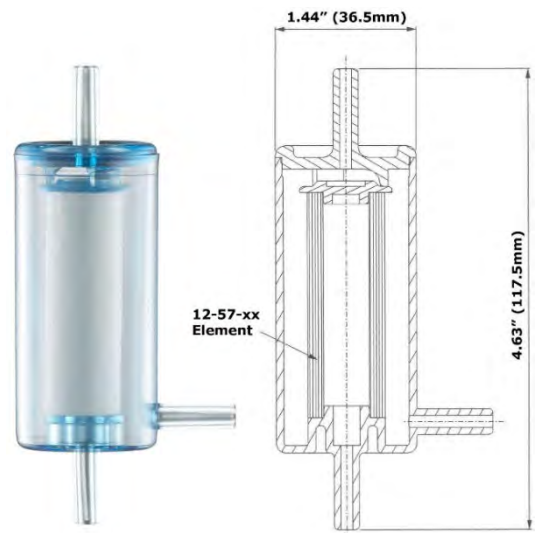

Maximum Flow with Microfiber Element

Our largest DIF is ideal for applications with high particulate loads or in remote locations where maintenance access is limited. Typical uses include ambient air monitoring and other harsh environmental conditions.

DIF-LN__ *add grade required

Standard Grade: DIF-LN60 (99.5% @ 0.01 Micron) - Other Grades Available: 30, 40, 50, 70, 80

TECHNICAL INFORMATION

- 1/4" NPT Inlet / Outlet or 1/2" Slip On Connection
- 120cc of Volume
- 230°F Maximum Temp. At 0 PSIG
- 100 PSIG of Maximum Pressure at 110°F
- 100% Grilamid TR 55 Blue Nylon body
- Fluorocarbon Borosilicate Glass Microfiber Element
- Standard Gas Flow at 100 PSIG is 17.0 SCFM (Grade 50)

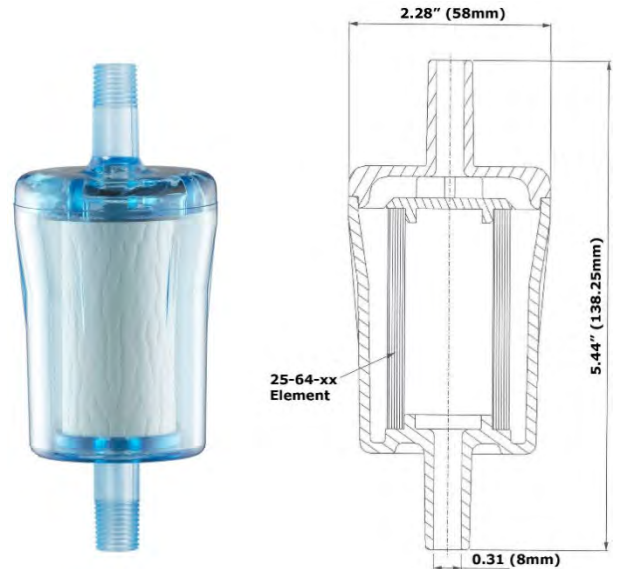

Maximum Flow DIF with Stainless Steel Screen

For applications where high-efficiency microfiber elements are not required, we offer economical stainless steel screens—commonly used for liquid sampling and pump protection.

DIF-LN__SS-1/4" *add micron required

For Portable Emission Analyzers: DIF-LN50SS-1/4. - Other Microns Available: 05, 10, 25, 100

TECHNICAL INFORMATION

- 1/4" NPT Inlet / Outlet or 1/2" Slip On Connection
- 120cc of Volume
- 230°F Maximum Temp. At 0 PSIG
- 100 PSIG of Maximum Pressure at 110°F
- 100% Grilamid TR 55 Blue Nylon body
- Fluorocarbon Borosilicate Glass Microfiber Element

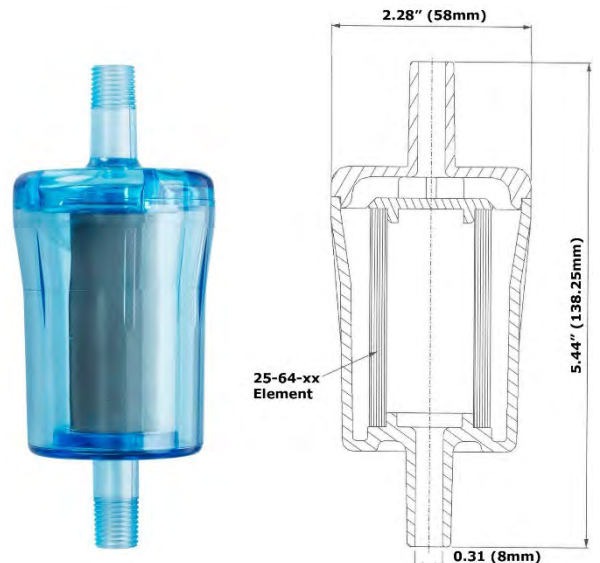

Maximum Flow Coalescing DIF

Our large DIF model with a third spigot is used in applications requiring coalescing (liquid removal), offering efficient separation in demanding environments.

New Kynar Version Available

To specify the Kynar construction, designate "LK". **Standard Grade Example:** *DIF-LK50C*

DIF-LN__C *add grade required

Standard Grade: *DIF-LN50C* (99.99% @ 0.01 Micron) - Other Grades Available: 30, 40, 60, 70, 80

TECHNICAL INFORMATION

- 1/4" NPT Inlet / Outlet or 1/2" Slip On Connection
- 1/4" Drain Port
- 120cc of Volume
- 230°F Maximum Temp. At 0 PSIG
- 100 PSIG of Maximum Pressure at 110°F
- 100% Grilamid TR 55 Blue Nylon body
- Fluorocarbon Borosilicate Glass Microfiber Element
- Standard Gas Flow at 100 PSIG is 17.0 SCFM (Grade 50)

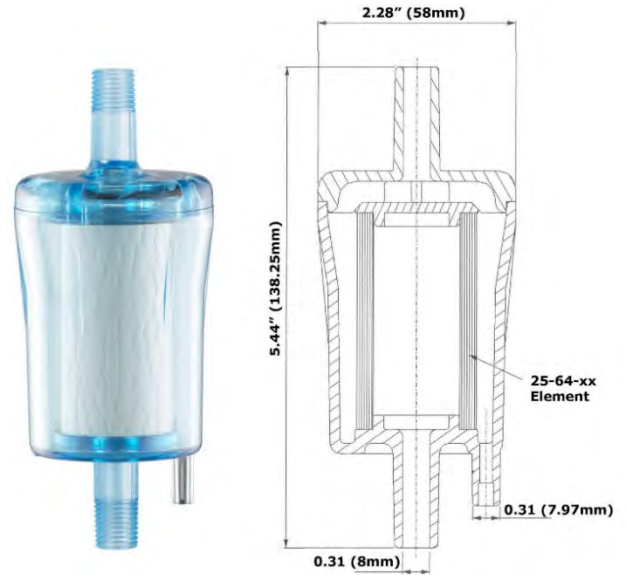

Maximum Flow with 1/4" Push Connect Fitting

This DIF model is specified for environments with extremely high particulate levels and serves as a direct replacement for the DIF-BN series. It comes complete with 1/4" push-to-connect (PTC) adapters for easy installation.

DIF-LN__-1/4" PTC *add grade required

Standard Grade: *DIF-LN60-1/4" PTC* (99.5% @ 0.01 Micron) - Other Grades Available: 30, 40, 50, 70, 80

TECHNICAL INFORMATION

- 1/4" Push Connect Fitting
- 120cc of Volume
- 230°F Maximum Temp. At 0 PSIG
- 100 PSIG of Maximum Pressure at 110°F
- 100% Grilamid TR 55 Blue Nylon body
- Fluorocarbon Borosilicate Glass Microfiber Element
- Standard Gas Flow at 100 PSIG is 17.0 SCFM (Grade 50)

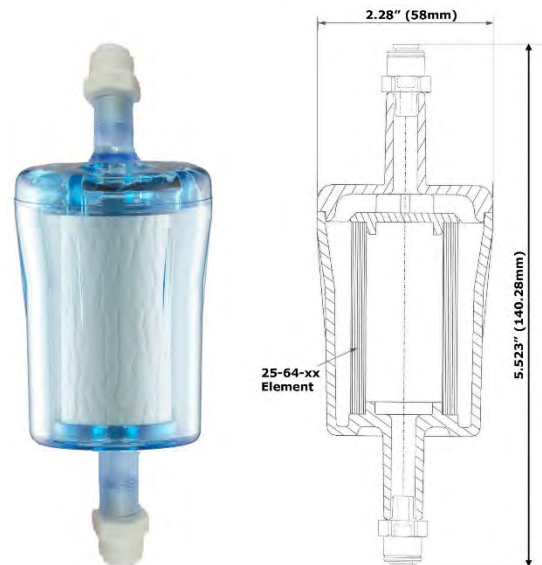

Maximum Flow for Chemical Compatibility

DIF-LK assemblies are constructed from black Kynar, making them ideal for corrosive environments. Compatible with a wide range of aggressive media, including (but not limited to) sulfuric acid, hydrochloric acid, chlorine (gas or liquid), and hydrogen peroxide.

DIF-LK__ *add grade required

Standard Grade: DIF-LK60 (99.5% @ 0.01 Micron) - Other Grades Available: 30, 40, 50, 70, 80

TECHNICAL INFORMATION

- 1/4" NPT Inlet / Outlet or 1/2" Slip On Connection
- 120cc of Volume
- 230°F Maximum Temp. At 0 PSIG
- 100 PSIG of Maximum Pressure at 110°F
- Black Kynar Body
- Fluorocarbon Borosilicate Glass Microfiber Element
- Standard Gas Flow at 100 PSIG is 17.0 SCFM (Grade 50)



Maximum Flow for Chemical Compatibility w/ PTFE Element

Constructed from black Kynar, DIF-LK assemblies are ideal for liquid sample filtration in environments where PTFE and Kynar are the only acceptable wetted materials.

DIF-LK__PT *add grade required

Standard Grade: DIF-LK25PT - Other Micron Available: 03PT

TECHNICAL INFORMATION

- 1/4" NPT Inlet / Outlet or 1/2" Slip On Connection
- 120cc of Volume
- 230°F Maximum Temp. At 0 PSIG
- 100 PSIG of Maximum Pressure at 110°F
- Black Kynar Body
- Teflon (PTFE) Element



Disposable In-Line Filters – Gas & Liquid Flow Rate Charts

GAS FLOW RATES – DIF-MN□ (12-16-□) – MINI

DIF Model Number	Filtration Efficiency Removal Of 0.01 Micron Particles	Gas Flow In SCFM At Stated PSIG With 1.5 PSID						
		1.5	20	40	60	80	100	125
DIF-MN30	99.99998+%	0.1	0.2	0.3	0.4	0.5	0.6	0.7
DIF-MN40	99.9999+%	0.15	0.3	0.5	0.7	0.8	1.0	1.2
DIF-MN50	99.99+%	0.3	0.6	1.0	1.0	1.7	2.1	2.8
DIF-MN60	99.5+%	0.4	1.0	1.6	2.1	2.7	3.4	4.1
DIF-MN70	95.0+%	0.5	1.1	1.8	2.4	3.0	3.7	4.7
DIF-MN80	75.0+%	0.9	1.3	2.0	2.7	3.5	4.3	5.0

LIQUID FLOW RATES (12-16-□) - MINI

DIF Model Number	Filtration Efficiency 98% Removal Rating	Water Flow Rates with 1.5 PSID
DIF-MN30	0.3 micron	0.6 GPH / 0.04 LPM
DIF-MN40	1 micron	1.6 GPH / 0.12 LPM
DIF-MN50	2 micron	3.3 GPH / 0.25 LPM
DIF-MN60	8 micron	6.5 GPH / 0.49 LPM
DIF-MN70	25 micron	8.0 GPH / 0.60 LPM
DIF-MN80	75 micron	8.5 GPH / 0.64 LPM

GAS FLOW RATES – DIF-BN□ (12-32-□) – STANDARD

DIF Model Number	Filtration Efficiency Removal Of 0.01 Micron Particles	Gas Flow In SCFM At Stated PSIG With 1.5 PSID						
		1.5	20	40	60	80	100	125
DIF-BN30 or BK30	99.99998+%	0.2	0.4	0.6	0.8	1.0	1.3	1.5
DIF-BN40 or BK40	99.9999+%	0.3	0.7	1.0	1.4	1.7	2.1	2.5
DIF-BN50 or BK50	99.99+%	0.6	1.3	2.0	2.7	3.5	4.2	5.7
DIF-BN60 or BK60	99.5+%	0.9	2.0	3.2	4.3	5.4	6.9	8.2
DIF-BN70 or BK70	95.0+%	1.1	2.3	3.6	4.9	6.0	7.5	9.4
DIF-BN80 or BK80	75.0+%	1.2	2.6	4.0	5.5	7.0	8.6	10.0

LIQUID FLOW RATES – (12-32-□) - STANDARD

DIF Model Number	Filtration Efficiency 98% Removal Rating	Water Flow Rates with 1.5 PSID
DIF-BN30 or BK30	0.3 micron	1.3 GPH / 0.10 LPM
DIF-BN40 or BK40	1 micron	3.2 GPH / 0.24 LPM
DIF-BN50 or BK50	2 micron	6.6 GPH / 0.50 LPM
DIF-BN60 or BK60	8 micron	13.0 GPH / 0.98 LPM
DIF-BN70 or BK70	25 micron	16.0 GPH / 1.21 LPM
DIF-BN80 or BK80	75 micron	17.0 GPH / 1.29 LPM

Disk Filters

PRODUCT FEATURES / BENEFITS

- ◆ Higher Volume than Standard Syringe Filters
- ◆ Exceptional Chemical Inertness
- ◆ Both Hydrophobic and Hydrophilic Membranes
- ◆ Pre-Use Pore Structure
- ◆ Point of Use Water Block
- ◆ Inlet / Outlet Vent Filter
- ◆ Liquid or Gaseous Sampling Applications

Disk Filters are an industry-standard, point-of-use solution for laboratory sampling and environmental applications. Designed for fine particle removal in demanding analytical workflows, each filter incorporates an advanced polytetrafluoroethylene (PTFE) membrane engineered for exceptional chemical resistance and precise filtration performance.

The naturally hydrophobic membrane delivers reliable operation with aggressive organic solvents, acids, and other chemical media that can compromise conventional filter materials. A lightweight polypropylene housing ensures the right balance of durability, chemical compatibility, and filtration capacity, making these filters well-suited for processing moderate sample volumes in high-performance laboratory environments.

Offering an economical and effective way to protect sensitive equipment, disk filters provide dependable results in critical applications.



Housing Model	GMBAF090203N	GMBAF090603N	GMBAF090303N
Materials of Construction	PTFE	PTFE	PTFE
Membrane Material	PTFE	PTFE	PTFE
Maximum Pressure (PSIG)	43	43	43
Maximum Temperature (°F)	140	140	140
Micron Size	0.22	1	.45
Diameter	50mm	50mm	50mm
Connection	Stepped Barb 5/16" to 1/2"	Stepped Barb 5/16" to 1/2"	Stepped Barb 5/16" to 0.45"
Non-Sterile (Yes or No)	Yes	Yes	Yes
Hydrophobic (Yes or No)	No	Yes	No
Filtration Area (CM2)	19.6	19.6	19.6
Bubble Point (Mpa)	>0.1	>0.15	>0.02
Flow Rate (ml/min/cm2@-0.093Mpa)	14.042	23.191	18.007

Syringe Filters

PRODUCT FEATURES / BENEFITS

- ◆ Both Hydrophobic and Hydrophilic Membranes
- ◆ Variety of Materials and Sizes Available
- ◆ Low Cost, Completely Disposable
- ◆ Interchangeable, Industry Standard Sizes
- ◆ Low Volume Particulate Sampling
- ◆ High Performance Liquid Chromatography (HPLC) Sampling
- ◆ Preparation of Aqueous and Organic Samples

Syringe filters are widely used in HPLC chromatography and other laboratory sampling applications. The UFS GME Series syringe filters are an industry-standard solution, delivering reliable and consistent microfiltration performance. Robust polypropylene housing withstands demanding filtration protocols while maintaining dimensional stability across temperature ranges up to 176°F (80°C).



A wide range of options is available, and our team can assist if a specific requirement is not listed below.

Housing Model	GMAAF040202N	GMAAF010602N	GMAAF040602N	GMAAF040601N
Materials of Construction	PTFE	Polypropylene	Polypropylene	Polypropylene
Membrane Material	PTFE	PTFE	PTFE	PTFE
Maximum Pressure (PSIG)	75	75	75	75
Maximum Temperature (°F)	230	230	230	230
Micron Size	0.22	1	1	1
Diameter	25mm	13mm	25mm	25mm
Connection	Luer Lok / Luer Slip	Luer Lok / Luer Slip	Luer Lok / Luer Slip	Double Luer Lok
Non-Sterile (Yes or No)	Yes	Yes	Yes	Yes
Hydrophobic (Yes or No)	Yes	Yes	Yes	No
Filtration Area (CM2)	4.08	2.12	4.08	4.08
Bubble Point (Mpa)	0.1	>0.15	>0.02	>0.02
Flow Rate (ml/min/cm2@-0.093Mpa)	N/A	N/A	N/A	N/A

Nylon Filter Housings

PRODUCT FEATURES / BENEFITS

- ◆ Filter Gases and Liquids
- ◆ Complete Nylon Construction
- ◆ Low Cost, Corrosion Resistant Filter Housings
- ◆ No Metal Contact Surfaces
- ◆ Replaceable Elements for Low Running Costs
- ◆ Emission / Environmental Filters
- ◆ Low Cost OEM Filters
- ◆ Point-Of-Use Instrument Air Filter

Nylon Housings provides an economical solution for both sample systems and low-pressure compressed air applications. Their durability, reliable performance, and price point the 700 series nylon filters offer an ideal OEM filtration solution. A wide selection of filter elements is available to accommodate even the most demanding requirements.

Each housing can be configured with two drain options:

- Manual Twist Drain
- No Drain (recommended for liquid filtration)



Model with Twist Drain	701N	710N	721N	730N	751N	760N	771N	780N
Model w/o Drain	700N	705N	720N	725N	750N	755N	772N	775N
Port Size (NPT)	1/8"	1/4"	1/8"	1/4"	1/4"	1/2"	1/4"	1/2"
Maximum Pressure (psig)	100	100	100	100	100	100	100	100
Internal Volume (cc)	40	40	52	52	150	150	290	290
Weight of Housing (lbs)	0.5	0.5	0.5	0.5	0.5	0.5	0.5	0.5
Principle Dimensions: (inches)								
Center Of Port To Head	0.39	0.39	0.39	0.39	0.61	0.61	0.61	0.61
Head Diameter	1.73	1.73	1.73	1.73	2.72	2.72	2.72	2.72
Overall Length Without Drain	3.78	3.78	4.41	4.41	5.86	5.86	9.92	9.92
Overall Length With Drain	4.25	4.25	4.92	4.92	6.34	6.34	10.35	10.35
Element Removal Clearance	1.50	1.50	2.01	2.01	3.07	3.07	7.21	7.21
Maximum Temperature (120°F) Standard Viton O-Ring	GV710	GV710	GV710	GV710	GV760	GV760	GV760	GV760
Filter Element Codes (1): Coalescing Element (Standard) **Other Elements Available- View Drawing**	12-32-□	12-32-□	12-57-□	12-57-□	25-64-□	25-64-□	25-178-□	25-178-□
Drawing **For More Detail & Options**	<u>701N</u> <u>700N</u>	<u>710N</u> <u>705N</u>	<u>721N</u> <u>720N</u>	<u>730N</u> <u>725N</u>	<u>751N</u> <u>750N</u>	<u>760N</u> <u>755N</u>	<u>771N</u> <u>772N</u>	<u>780N</u> <u>775N</u>

Notes: (1) Replace '□' with grade required, e.g. 12-32-50C

Nylon Emission Filter Housings

PRODUCT FEATURES / BENEFITS

- ◆ Filter Emission Gases
- ◆ Low Cost, Corrosion Resistant Filter Housings
- ◆ Complete Nylon Construction, No Metal Contact Surfaces
- ◆ Replaceable Elements for Low Running Costs
- ◆ Durable, Threaded Head to Bowl Connection
- ◆ Accepts Disposable Microfiber Elements
- ◆ Engine Emission Testing
- ◆ Portable Analyzer Protection
- ◆ Ideal Dual Stage Compressed Air Filter

Our OEM Nylon Emission filters are specifically designed for gasoline engine analysis. We offer a traditional T-Type design or our unique inverted configuration.

The 745N (1/4") and 746N (1/2") are single-element assemblies designed to accept industry-standard element sizes and grades, ensuring complete interchangeability. With their compact footprint and low internal volume (108 cc), these housings are particularly well suited for portable emission systems. Based on the 750N design (see first page), the short-bowl 745N and 746N are mounted in the traditional T-type format.

The 707N and 778N utilize our unique inverted 2 stage element design within one housing. Eliminating the need to break a connection for service or draining liquids. A secondary benefit is the unit having two elements, a coalescing pre-filter and particulate final filter. This minimizes internal volume and less leak pints since only one body is utilized.



Housing Model	745N	746N	707N	778N
Port Size (NPT)	1/4"	1/2"	1/4"	1/4"
Drain (NPT)	No Drain	No Drain	1/8"	1/8"
Maximum Pressure (psig)	100	100	100	100
Internal Volume (cc)	108	108	60	115
Principle Dimensions: (inches)				
Port to Top of Head	0.61	0.61	0.59	0.59
Head Diameter	2.72	2.72	1.73	2.36
Overall Length	4.75	4.75	3.54	4.53
Element Removal Clearance	3.07	3.07	2.36	2.75
Maximum Temperature (120°F) Standard Viton O-Ring	GV745	GV745	GV707	GV778N
Filter Element Codes: Coalescing / Particulate Element (One of Each) *Other Elements Available- View Drawing*	25-64-□	25-64-□	12-25-80C / 12-32-60K	25-35-80C / 25-30-60K
Drawing **For More Detail & Options**	745N	746N	707N	778N