



Model 151SCK

Technical Data

- 316L Stainless Steel Construction
- 1 1/2" NPT / 1/4" NPT Drain
- 1500 PSIG Maximum Pressure
- Internal Volume (with Tie Rod / No Element): 1350cc
- Viton O-Ring (Standard-Included)
- Total Weight: 22 lbs.
- Flow Rate @ 100 PSIG: 340 lbs/hr.
 - Based on 51-213-70ZZ Standard Coalescing Grade Element

Elements Available:

51-213-70ZZ	Disposable Borosilicate Glass Microfiber Filter Element 51-213-70ZZ – Standard Steam Coalescing Filter Element
SS-51-213- xx T	Stainless Steel Filter Element Comes Standard with Teflon Seals "T", Add "V" for optional Viton Seals when Ordering Micron Sizes: 005, 01, 03, 10, 25, 50, 100 and 200
51-213-70ZZX3	Reinforced Borosilicate Glass Microfiber Filter Element With Interior & Exterior Stainless Steel Cages

Replace "**xx**" with micron needed. See [Filter Element Guide](#) for more information.

Available O-Rings:

GV150	Viton (-15°F to 400°F) **Standard - Included**
BN150	Buna-N (-40°F to 250°F)
KZ150	Perfluoroelastomer (5°F to 600°F)
GS150	Silicone (-65°F to 400°F)
GE150	EPDM (-65°F to 300°F)

The 150SCK internals are modified to accept our 51-213-70ZZ Steam Coalescing Element.

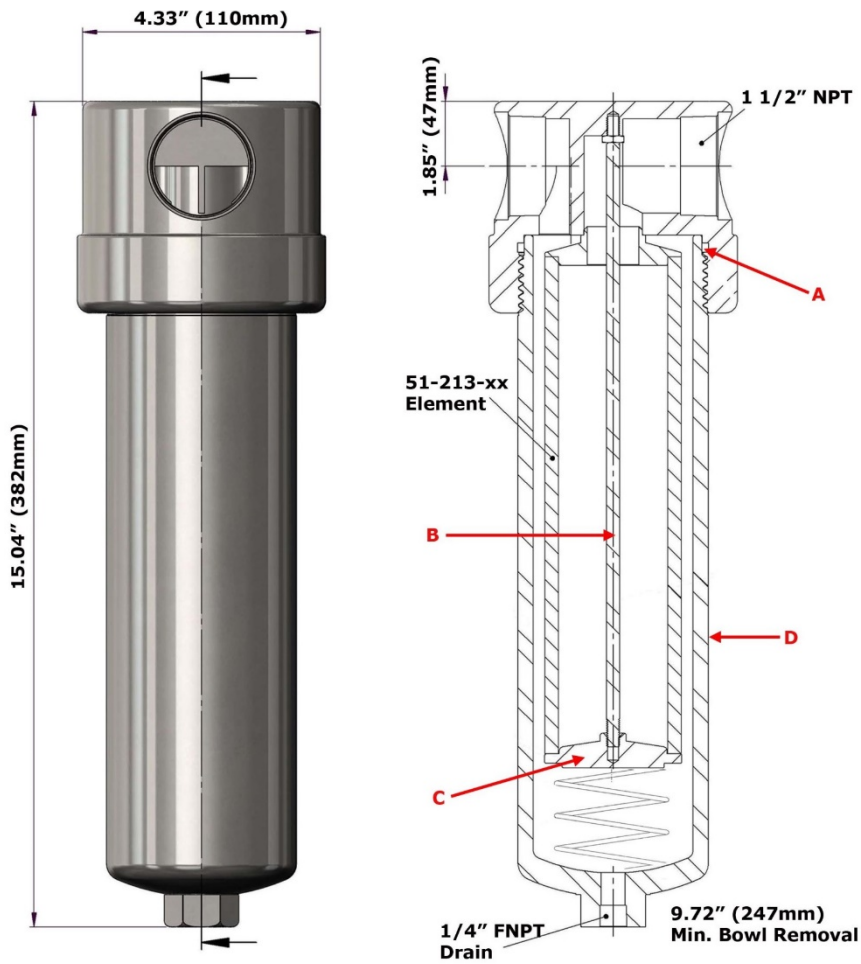

Replacement Parts:

GV150	Viton (-15°F to 400°F) (A) **Standard - Included**
TR150SCK	Stainless Steel Tie Rod (B)
ER150SL	Stainless Steel Spring Loaded Element Retainer (C)
SSB150	Stainless Steel Bowl (D)

Accessories:

SC150	Stainless Steel Support Core
MBSS150	Stainless Steel Mounting Bracket (M10-1.5 x 15 Full Thread on 2.50" Center @ 90° to Port)