

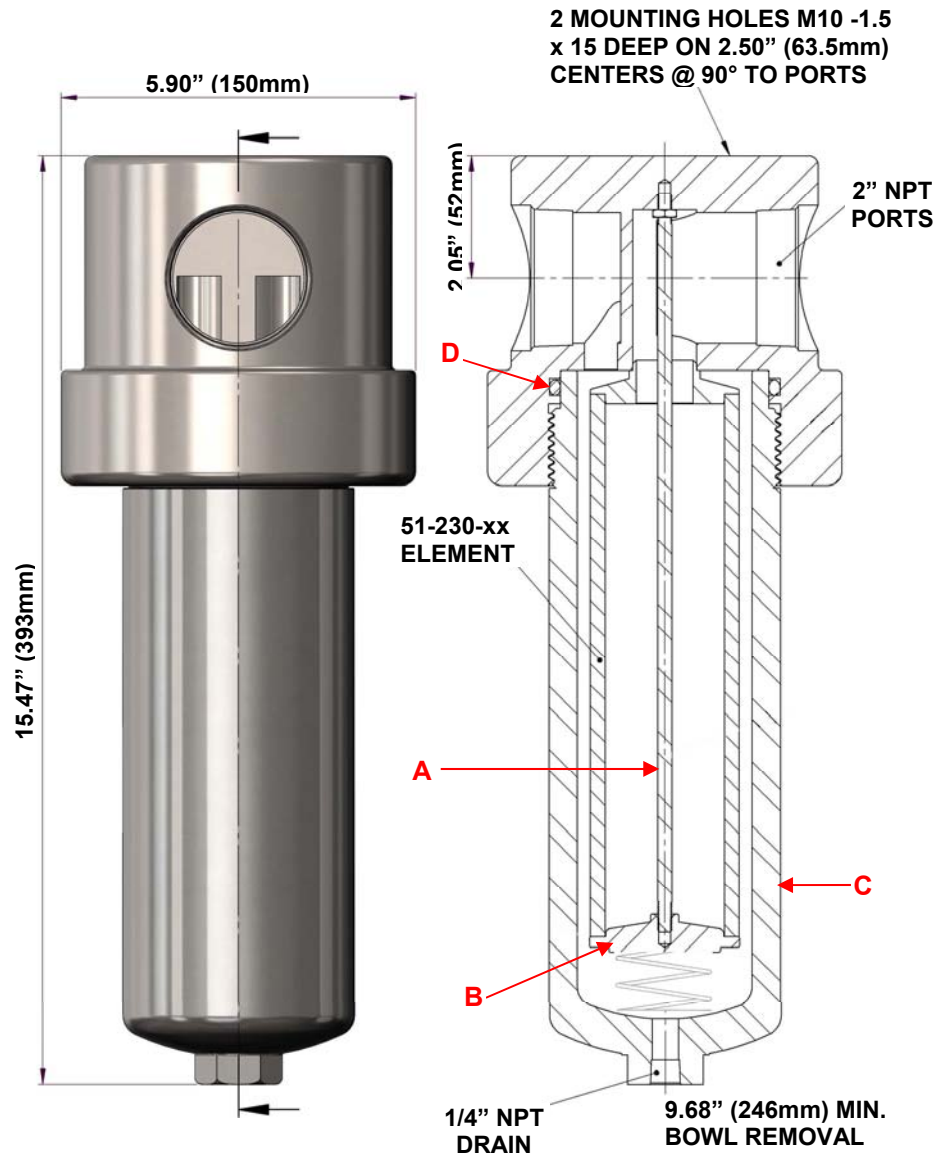

Model: 152HP (2" NPT)

Replacement Parts List

51-230-xx	Disposable Filter Element
SS-51-230-xx	Stainless Steel Filter Element Comes Standard with Teflon Seals "T" Add "V" for optional Viton Seals when Ordering
51-230-xxPL-MG-RV	Pleated Micro-Glass Element
51-230-xxPL-SS-RV	Pleated Stainless Steel Element
TR150	Tie Rod (A)
ER150SL	Spring Loaded Element Retainer (B)
SC150	Support Core (Not Pictured)
SSB 152HP	316L Stainless Steel Bowl (C)
MB150	Mounting Bracket (Not Pictured)
Oxygen Cleaning Service Available Note – Please replace "xx" with micron rating or grade	
Available O-Rings	
BN150HP	Buna-N
GV150HP	Viton (Standard) (D)
KZ150HP	Kalrez
GS150HP	Silicone
GE150HP	EPDM



Please Note: Exotic Materials are available, for Hastelloy-C (152HP-HC) and for Monel (152HP-M).

 <p>United Filtration Systems, Inc. 6558 Diplomat Drive Sterling Heights, MI 48314 1-800-311-5561 www.unitedfiltration.com</p>	Model 152HP		<p>THE COPYRIGHT OF THIS DRAWING IS RESERVED BY UNITED FILTRATION. IT IS ISSUED ON CONDITION THAT IT IS NOT COPIED, REPRODUCED OR DISCLOSED TO A THIRD PART EITHER WHOLLY, OR IN PART WITHOUT CONSENT IN WRITING.</p>
	<p>Material: Head: 316L Stainless Steel Bowl: 316L Stainless Steel Internals: 316L Stainless Steel Standard Gasket / O-ring: Viton</p>	<p>Drain Type: 1/4" NPT Maximum Temperature: 400°F Maximum Pressure: 3000 PSIG Internal Volume: 1500 cc Weight: 34 lbs.</p>	
<p>DO NOT SCALE DRAWING IF IN DOUBT ASK</p>		<p>Drawn By & Date UFS0923Y</p>	